

LIGHT BARRIER FC180

SYNCHRONIZED RX - TX

INSTRUCTION MANUAL

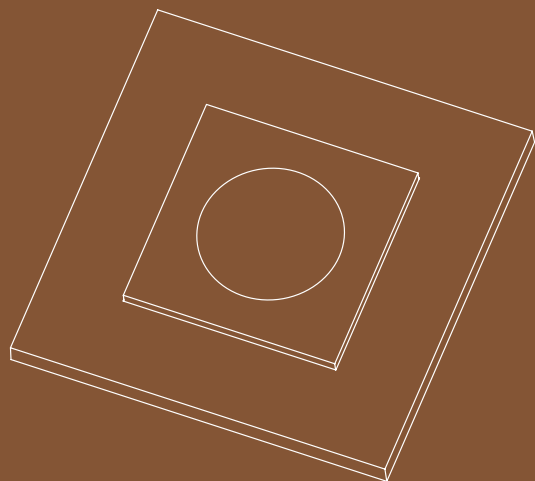

SMINN

innovative in electronics

DESCRIPTION

SMINN'S FC180 light barrier is composed by a RX receiver and a TX emitter.

Devices that are built using high quality materials and components and the latest technology. They are made taking into account the current regulations for usage in residential, commercial and light industry environments.

OPERATION

Once the light barrier is correctly installed, the emitter sends a beam of infrared light modulated by pulses to the receiver, setting up a safety barrier.

Each time the light beam is broken the receiver activates the internal red led and activates the alarm relay. All regulations on security of the installation must be strictly observed.

APPLICATIONS

The FC180 light barrier has been designed for protection in automatic doors, barriers and blinds. It can be used for access detection in alarm systems and traffic control, if the distance between emitter/receiver is not more than 15 meters.

INSTALLATION

Check the integrity of the product to be installed.

- Place it away from heat sources, humidity or excessive radiation and to a minimum height of 30-40 cm from the floor, preventing reflection problems with the light beam.

THE MANUFACTURER IS NOT RESPONSIBLE
OF THE DAMAGE CAUSED BY AN INCORRECT
INSTALLATION OR IMPROPER OR CARELESS USE

- Avoid GASES or INFLAMMABLE PRODUCTS, as they are a serious danger for security in electric installations.
- Place emitter and receiver one in front the other, in the same axis and the same height.

NOTE: the operating distance can be reduced because of external, adverse conditions such as dust, excess of light, rain, fog, etc.

- Select the synchronous mode with the Jumper that connects the terminals 3 and 4 only if it is powered with an AC power supply. See Fig.2

Jumper J2	ON	continuous mode in AC and DC
Jumper J2	OF	synchronous mode only in AC

- With the synchronous mode, the emitter will project a beam of light modulated only in one of the half-cycles of AC current. That allows to install two sets of light cells very close to each other without interferences.

Installing two sets of light cells:

If we install two sets of light cells, we should proceed as follow:

Powered with an AC power supply

In this case it is recommended to use the synchronous mode and install the emitters in one side and the receivers in the other one, but reversing their power supplies **Fig. 2**

Powered with direct current DC

In this case, the terminals 3 and 4 of the emitters have to be joined so they work in CONTINUOUS mode, and they should be installed in different sides of the gate so they do not interfere between them. See Fig 1

Connect as indicated in the attached diagram, depending on the type of installation. Lastly, connect the power supply to the system and check if it works correctly.

OPERATION VERIFICATION

To verify the system is operating, interrupt the beam of light and check that the relay commutation activates. The receiver's alarm relay will be in open mode if there is not visibility between emitter/receiver. It closes contact when the beam of light is uninterrupted.

MAINTENANCE

Even though this product doesn't need any special maintenance, it is a good idea to keep in mind the instructions given by the installer, manufacturer and current laws about maintenance, repairs and device cleaning and documental control.

WARRANTY

This product has undergone a complete TEST during its manufacturing process that guarantees its reliability and proper operation.

The manufacturer provides 24 months of warranty to the product from the date printed in the product and against any anomaly that it may present in its appearance or operation.

Any damage caused by third parties, natural causes (flooding, fire, lightning, etc), arising from improper handling or installation, vandalism or any other cause not attributable to the manufacturer will void the warranty.

The warranty only covers repairs or replacement of the damaged device. Any expenses derived from assembling, travelling, transport, natural wear of parts, etc., and, in general, any expenses that are not part of the repairs or replacement of the damaged element of the system are excluded.

The installer/provider will ask the manufacturer for an **RMA** number or authorization for transport of the system in warranty. Without this previous requisite, the manufacturer will not be able neither to process nor provide warranty service.

WARNING

This product must be used in installations which has been conceived for, considering any other as improper use. The packaging and wrapping **MUST NOT** be dumped in the environment.

Keep products, packaging, wrapping, documentation, etc., out of the reach of children.

Follow the current local, national or European regulations.

The information contained in this document may have some mistakes that will be corrected in future editions.

The manufacturer keeps the right to modify the content of this document or the product without prior warning.

WASTE ELECTRICAL AND ELECTRONIC EQUIPMENT DIRECTIVE (WEEE)

In accordance with the European Directive 2002/96/EC about waste electrical and electronic equipment (WEEE), the presence of this symbol (see symbol at the bottom of this text) in the product or in the packaging, means that this article shall not be disposed in local non-classified waste streams. It is the user's responsibility to dispose this product taking it to a collection point designed for waste recycling of electrical and electronic devices. The separate collection of this product helps optimize the waste sorting and recycling of any recyclable material and also decreases the impact on health and the environment.

For more information about the correct wasting of this product, please contact the local authority or the distributor where you acquired this product.



EC DECLARATION CONFORMITY

The company **ELSON SISTEMAS, S. L.**
Pol. Ind. Torrelarragoiti, P6 · A3 · 1ª
48170 Zamudio – Vizcaya
(SPAIN)

Declares that

The product **FC 180 Synchronized light barriers**
Manufactured by **ELSON ELECTRÓNICA, S.A.**
Under the trademark **SMINN**
Created for **Residencial, comercial and industrial use.**

This device meets the provisions contained in the article 3 of the R&TTE 1999/05/CE Regulation, as long as its usage is compliant to what was envisaged, having applied the following regulations:

Electromagnetic Compatibility **EN 301 489-3 v1.3.1 (2001-11)**

Low Tension **EN 60730-1 (2000)**

Zamudio 2010.03.30

José Miguel Blanco Pérez
Chief Technical Officer

SMINN

innovative in electronics

Elson Sistemas
T. +34 944 525 120
www.sminn.com
info@sminn.com
Pol. Torrelarragoiti, P6 - A3 - 1ª
48170 Zamudio - Vizcaya (Spain)

TECHNICAL CHARACTERISTICS

Range	15 m
Supply	12/24 V AC/DC
Power	TX+RX lower than 50 mA
Casing	PA6 + 30% FV PC infrared+ filtro UV
Ingress protection	IP45
Size	H85 x W85 x Z27 mm
Infrared beam	880 nm
Freq. modulation	600 Hz
Contact relay	0.5 Amp
Propagation delay	< 20 ms
Operating temperature	-20/ +70°C

Fig. 1 DC Installation
Continuous mode

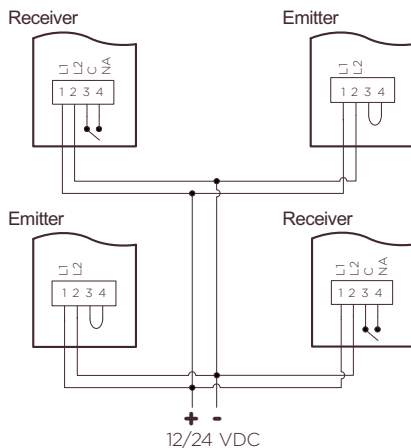
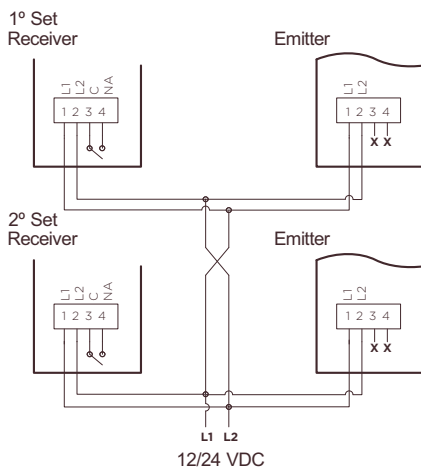

Fig. 2 AC Installation
Synchronous mode



IMPORTANT. Do not connect anything to the 3 and 4 terminals (fig. 2)

Fig. 3 Operating distance



Fig. 4

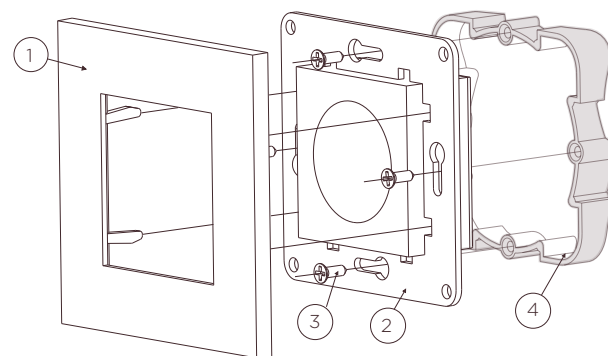

1. Frame
2. Light barrier body
3. Fixing screws
4. Wall universal plug box

Fig. 5 Front view of the devices

