

BOX L VF1L EI/EA

UNIVERSAL CONTROL PANEL

For gates with 1 three-phase 230VAC motor with frequency converter

INSTRUCTION MANUAL



SMiNN

innovative in electronics

COMPONENTS SITUATION

Fig.1

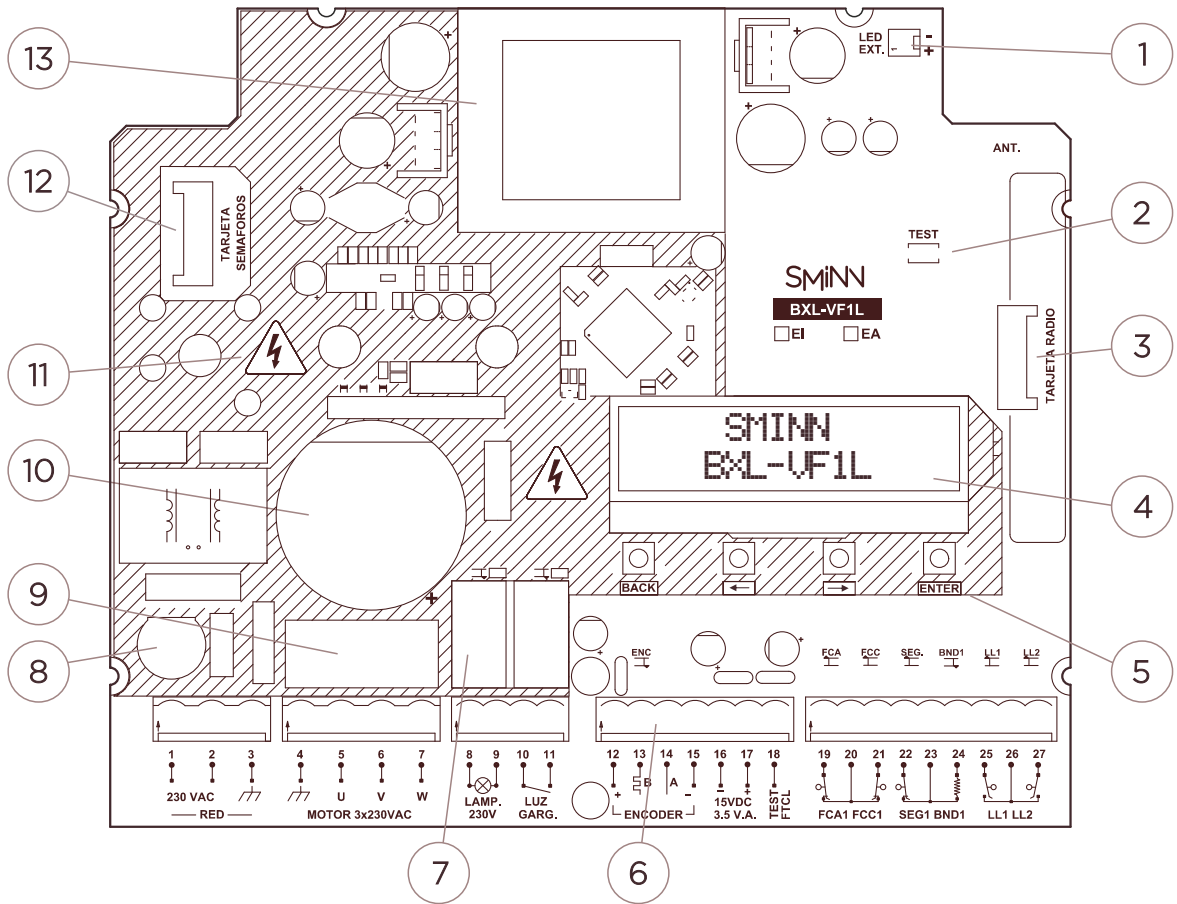

- 1. LED connector for panel cover
- 2. TEST Run button
- 3. TRSH radio card socket
- 4. LCD display
- 5. Options selection keypad
- 6. Connection terminals

- 7. Auxiliary output relays
- 8. AC power input fuse
- 9. Bus load relay
- 10. Bus capacitor
- 11. High voltage zone 230VAC
- 12. Traffic light card socket
- 13. Power transformer







INDEX

Description	2
Limitation on the use of the panel	2
Warnings	2
Installation	3
Important safety instructions for installation	3
Important safety instructions for use	3
Wiring	4
Setup	6
Maneuver programming	7
Maneuver	8
Activation	8
Maneuver modes	8
Phases	9
Safety test	9
Unlocking	9
Movement	9
Safeties	11
Stop	11
Light barriers	11
Safety edges	12
Current sensor	12
Encoder	13
Motor	13
Outputs	16
Display	17
Encoder	17
Electrical wiring diagram	14
Light barrier power wiring	14
Accessories and peripherals	15
Options	18
Timings	20
Maintenance	22
Error log	23
Light barrier shielding	24
Warranty	25
Waste of electrical and electronic devices	25
Notes	26
Technical characteristics	28
CE declaration of conformity	28
Parts exploded view	29

FIGURE INDEX

Figure 1	0
Figure 2	14
Figure 3	29

Symbols

 Encoder pulses
 Relay output (NO contact)
 Safety edge
Normally open contact
Normally closed contact
 Earth
 High voltage area

DESCRIPTION

The BXL-VF1L / BXL-VF1L-EA universal control unit is designed to be part of an automation system for up-and-over, ascending or sliding gates with a 230VAC three-phase motor.

The table has the following features:

- ♦ Control of 1 three-phase 230VAC motor up to 0.75kW (delta connection).
- ♦ Intuitive multi-lingual programming menu via 4 keys and backlit LCD display.
- ♦ 1-channel incremental encoder support in the VF1L version and absolute encoder support in the VF1L-EA version.
- ♦ Independent regulation of power and speed in opening and closing.
- ♦ Configurable test of safety devices before each opening or closing.
- ♦ Two independent key inputs for different activation modes.
- ♦ Output for 230V flashing lamp and output for garage light contact reprogrammable to other functions.
- ♦ Socket for SMINN radio card (6 pins).
- ♦ Independent inputs for one photocell and one strip (resistive or contact) or a second photocell.
- ♦ LEDs indicating the status of the inputs and outputs of the panel.
- ♦ 15VDC (3.5W) peripheral power output protected by resettable fuse.
- ♦ Optocoupled inputs with high electrical isolation.
- ♦ Storage of number of manoeuvres (partial and total) and events to facilitate maintenance. Configurable maintenance signal on external LED.
- ♦ Manoeuvre learning system that facilitates commissioning and configuration.
- ♦ Obstacle detection with configurable sensitivity by amperometric sensor and/or encoder.

LIMITATIONS ON THE USE OF THE CONTROLLER

Use is not guaranteed when installed on equipment other than that specified.

The manufacturer reserves the right to change the specifications of the switchgear and this manual without prior notice. The switchgear must only be handled by specialised and/or suitably instructed personnel.

WARNING

The product must be used for its intended purpose and any other use is considered inappropriate. Packaging and containers must not be disposed of in the environment. Keep products, packaging, containers, documentation, etc. out of the reach of children. Observe applicable local, national and European regulations. The information contained in this document may contain errors which will be corrected in subsequent editions. The manufacturer reserves the right to modify the contents of this document or the product without prior notice.

SMINN CONTROL PANELS ARE EQUIPPED WITH AN INDICATOR LIGHT THAT LETS US KNOW IF THE EQUIPMENT IS POWERED

THE INSTRUCTIONS FOR USE OF THIS EQUIPMENT MUST BE GIVEN TO THE USER. IN CASE OF LOSS, THE USER MAY REQUEST A COPY OR DOWNLOAD THEM DIRECTLY FROM THE WEBSITE WWW.SMINN.COM.

INSTALLATION

The box is fixed to the wall with only three screws, all of them external (see Fig.3).

Drill three holes in the wall according to the cut-out template printed on the bottom of the box. Use the screws and plugs supplied.

Cut out the rubber plugs located at the bottom of the box and pass the cable conduit through them into the equipment. Observe the safety instructions for installation.

Connect the power, motor and device cables to the terminals on the terminal strips as indicated on the printed circuit board. Refer to the following sections of the manual for wiring and configuration specific to each element.

Power the panel and the ON LED will light up (See Fig.1). For the initial operation check, connect at least the motor, the brake (if necessary) and the limit switches or absolute encoder (VF1L-EA) and use the keys -> to open and <- to close in dead man's mode, checking the operation of the motor (in slow speed and dead man's mode).

Connect the rest of the automation elements and carry out a learning manoeuvre to start up the control panel. After finishing, customise the configuration if necessary.

IMPORTANT SAFETY INSTRUCTIONS FOR INSTALLATION

Before installing the panel::

- ♦ Check that the door/blind is in good mechanical condition and properly counterbalanced.
- ♦ Remove everything that is not necessary from the environment and switch off the AC power.
- ♦ Install the panel at a minimum height of 1.5 m, preferably next to the door.
- ♦ Use power and motor cables of suitable cross-section.
- ♦ Power the panel via a circuit breaker/emergency switch that is easily accessible by the user.

The European door standards EN 12453 and EN 12445 specify the minimum levels of protection and safety for doors installed

in single-family dwellings and communal and public facilities. The moving door must be prevented from making contact with any object or limiting the contact force (e.g. safety edge), and in the case of automatic closing, it is necessary to supplement it with a presence detector (e.g. photocell).

Check that the configured photocells and strips act by means of the LED associated with each of these inputs. The LEDs of the strips will not activate if this strip has not been previously activated in the menu (See Fig.1).

Make sure that the safety edge is not activated when the door is completely closed.

Once the manoeuvre programming and configuration have been carried out, test the manoeuvre using the TEST button (Fig.1), or using the appropriate key input to validate that the configuration and operation are correct.

IMPORTANT SAFETY INSTRUCTIONS FOR USAGE

Once the mechanism is installed and as a precaution, the user must:

- ♦ Keep the control mechanism out of the reach of children.
- ♦ Monitor the movement of the door, keeping the area clear of people and objects.
- ♦ Exercise caution when operating the door manually (unlocked) as it may move uncontrollably due to the weight of the door, the condition of the fixings, springs and counterweights.

If a malfunction of the system is observed, the user should IMMEDIATELY contact the technical support service. The mechanism must not be used as it may cause damage.

WIRING

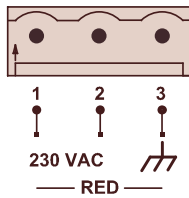

The panel is supplied with 230VAC 50Hz via terminals 1 and 2. The earth connection is made at terminal 3.

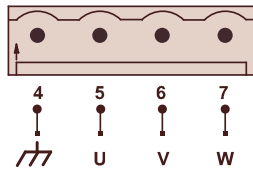

The control unit can control a three-phase 230VAC motor. Connect the three phases to terminals 5, 6 and 7 and connect the earth terminal 4 to the motor housing. If the direction of rotation is incorrect, swap two of the phases.

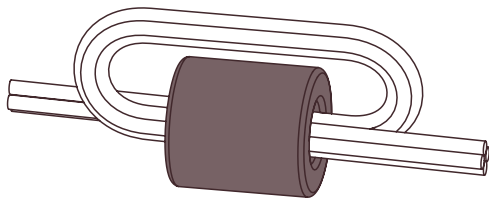

NOTE: In order to comply with European standards regarding electromagnetic interference, it is mandatory to pass the motor cables back through the ferrite core included with the product.

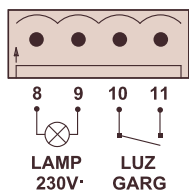

The control unit has a 230V output via a relay for a flashing lamp and a potential-free contact for a garage light that can be configured for other functions. These relays can withstand 10A over 230VAC or 5A over 30VDC.

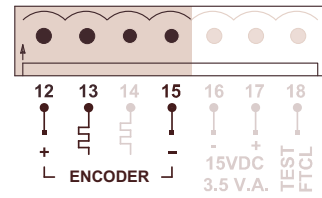

VF1L: Terminals 12 and 15 provide an incremental encoder with 12VDC power supply. Terminal 13 is used to connect the incremental encoder signal.

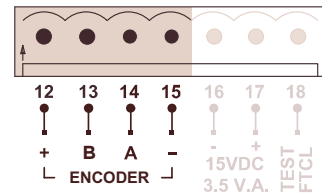

VF1L-EA: Terminals 12 and 15 provide an absolute encoder with 12VDC power supply. Terminals 13 and 14 are used to connect the RS485 signals of the encoder. For correct operation it is necessary to connect each terminal to the encoder terminal marked with the same symbol (A to A and B to B).

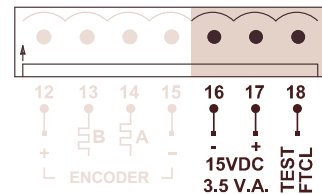

At terminals 16 and 17, the panel has a voltage output for peripherals of 15VDC - 3.5VA protected by a resettable fuse for powering external circuits such as photocells.

Additionally, terminal 18 serves as a specific negative for photocell testing. According to standard.

WIRING

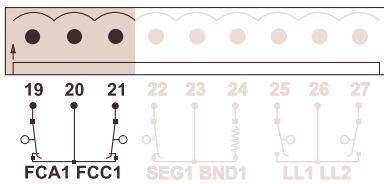

The panel has inputs for opening and closing limit switches. The contacts are normally closed and have a common for ease of installation.

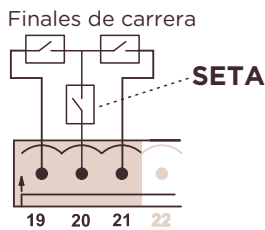

It is possible to install an emergency stop button interrupting both limit switches at the same time.

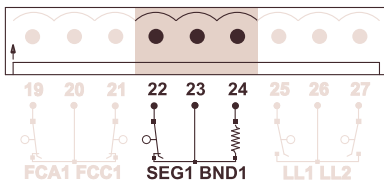

The control unit distinguishes two groups of safety devices, edge and photocell, with the same common connection. The strip can be configured as resistive or contact and the photocell is always a normally closed contact. See options.

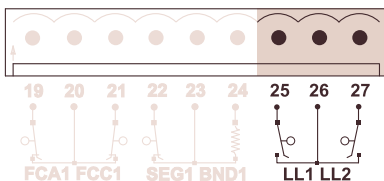

Terminals 25 and 26 are used to connect a push button to activate the complete manoeuvre and terminals 26 and 27 to activate the pedestrian opening or closing in dead man's mode.



The radio card socket allows a SMINN radio card (6 pins) to be plugged in, enabling the opening command to be given via radio transmitters.



The traffic light card socket enables the connection of different traffic light cards for the following functions:

- TSMF20: Control of one red and one green light.
- TSMF40D: Discriminating control of two red and two green lights.
- TSMF40E: Potential-free signals for door open, closed, opening and closing.

CONFIGURATION

To facilitate the configuration and maintenance of the panel, it has an advanced menu system accessible by means of an integrated 4-key keypad and data presentation on a backlit LCD display that allows the panel to be configured simply, quickly and intuitively.

Press the BACK + ENTER keys simultaneously to access the configuration menu. The LCD will light up. To move through the menu, the panel has 4 keys which are:

BACK (exit)

ENTER (accept)

<- (back)

-> (forward)

While using the configuration menu, the two lines of the screen are normally used; on one of them, the symbols < and > will appear at the ends to indicate that the user is navigating on that line. Navigating on the top line navigates between menus and parameters (with the current value, if applicable, appearing on the bottom line). Navigating on the bottom line navigates between the possible values of the selected parameter, shown on the top line.

Therefore, the <- / -> keys are used to move between the elements of the current navigation level, the ENTER key is used to select an element or validate the selection of a value, and the BACK key is used to cancel the modification of a parameter and, in general, to go backwards.

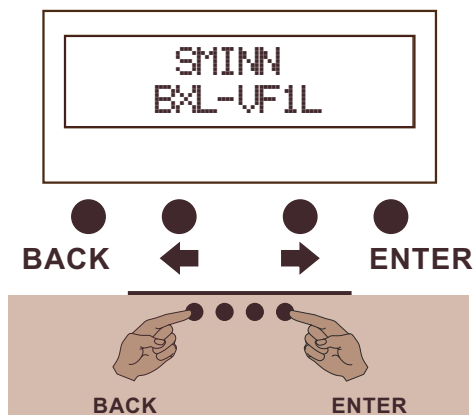

Temporarily and depending on its use, the installation must be subjected to a complete operation test by qualified personnel in order to detect any signs of wear or deterioration.

If for any reason the panel needs to be repaired, contact the manufacturer or the nearest official service centre.

Once the manoeuvre has been programmed, we must ensure that the power and soft stop settings are suitable for compliance with standard EN 12453:2018+A1:2022, taking the measurements in accordance with the method described in the standard. See force graph.

If, due to the characteristics of the installation, these values are not met, additional protection elements must be installed.

The dynamic force F_d must not exceed the following measurements:

< 400N in spaces between 5-50cm

< 1400N in spaces larger than 50cm

Force diagram

F_d : Dynamic force

F_s : Static force

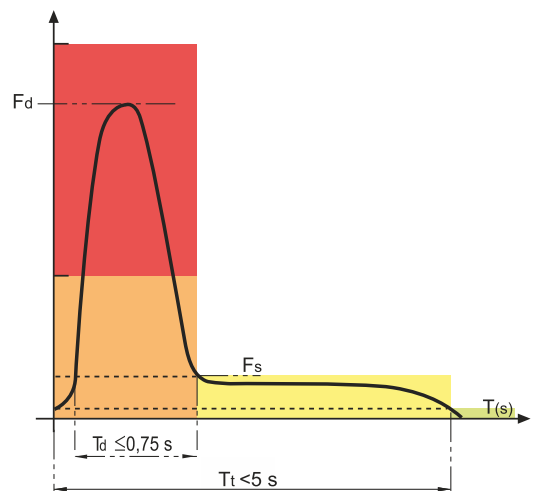

MANOEUVER PROG.

The control panel has a configuration wizard that allows you to select the most important parameters and start up the control panel quickly.

To start the wizard, with the door closed, enter the configuration menu by pressing **BACK+ENTER**, the parameter **GATE TYPE** will appear.

Press **ENTER** and use the **</->** keys to scroll through the options until the desired type is selected. Press **ENTER** to validate. Then press **->** and **MANIOB MODE** will appear.

Press **ENTER** to access the submenu and use the **</->** keys to select the desired mode. Press **ENTER** to validate. Then press **->** until the **MAINTENANCE** menu appears. Press **ENTER** to access the submenu. Press **->** to select the **OPEN** and/or **CLOSE** commands.

In either command, pressing **ENTER** will operate the door (opening or closing) in deadman mode at soft stop speed and power. In this way it is checked that the connections of the phases to the motor are correctly made and the direction of rotation of the motor is correct, or not, in which case the parameter **INVERT MOTOR** can be used or any 2 phases can be swapped between them.

Once these steps have been carried out, press **->** until **PROG MANEUVER** appears on the screen and accept by pressing **ENTER**.

After this, the panel will ask one by one for the vital parameters of the configuration. Choose the desired value for each option with the **<-** and **->** keys and press **ENTER** to accept and continue or **BACK** to go back.

If the door interrupts the photocell installed at input **S1** during its movement, it is possible to configure the panel to learn the inhibition interval automatically by setting the parameter **INHIB. SEG1** parameter to **YES**.

In the case of the **VF1L-EA** version with absolute encoder enabled, the panel will instruct you to position the door at the

opening and closing points using the **<-** and **->** keys to memorise their positions.

After configuring the basic parameters, the panel will indicate that after pressing **ENTER** again, the learning manoeuvre will begin.

From here you can carry out the following steps using the **ENTER** key, the **LL1** key input, or by means of a radio transmitter:

- Press to start opening.
- Press to start soft stop (if the parameter **SOFT STOP** is activated).
- Wait until the opening limit switch is reached (the door will stop by itself).
- Press to start closing.
- Press to start soft stop (if parameter **SOFT STOP** is activated).
- Wait until the closing limit switch is reached (the door will stop by itself).
- The control panel will record by default both the opening and closing time (with a 10% increment) as a safety measure in case of failure in the limit switches.

The programming manoeuvre will change the following parameters:

- **TOTAL PULSES**
- **SOFT STOP AP**
- **SOFT STOP CR**
- **M1 SENSIB.**
- **M1 LIM. PRES.**
- **OPENING TIME** (with a 10% increase)
- **CLOSING TIME** (with a 10% increase)
- **POLARITY ENC** (for the **VF1L-EA** model)
- **ENC ABS POS I** (for the **VF1L-EA** model)
- **ENC ABS POS F** (for the **VF1L-EA** model)

MANOEUVRE

ACTIVATION

The key inputs (marked LL1 and LL2) and a radio card installed in the radio socket can be used to start a manoeuvre when the control unit is idle.

The functions of the key inputs LL1, LL2 and the radio card are determined by the selected manoeuvre mode. It is possible to disable any of the LL1 or LL2 inputs using the **LL1 BLOCK** or **LL2 BLOCK** parameters, so that any stimulus on these inputs will be ignored.

Each input is assigned a transit direction to enable the use of discriminating traffic lights. LL1 and the radio card are used for the incoming transit direction and LL2 for the outgoing transit direction (only in **DISCRIM. STD.** mode).

NOTE: The radio card operates by default in the same way as LL1 unless the **RADIO ALT STOP** parameter is activated, in which case it will operate in alternate stop (regardless of the general manoeuvre mode selected).

MANOEUVRE MODES

The **MANOEUVRE MODE** parameter sets the functions that the key and radio inputs perform.

STANDARD

In **STANDARD** mode, LL1 will give an open command if the door is closed and a close command if the door is open and at rest. LL2 will function the same except that the opening will be in pedestrian mode. Either input will perform a soft reversal manoeuvre when activated during closing. In this mode, **AUTO CLOSE** is activated by default, although in **OPTIONS**, by accessing this command, it can be deactivated by selecting **NO**.

STANDARD DISCRIMINATORY

The **DISCRIM. STD.** mode is the same as the **STANDARD** mode, except that LL1 and LL2 perform the same function; the former in the input direction and the latter in the output direction.

OPEN/CLOSE

The **OPEN/CLOSE** mode uses LL1 as the opening command and LL2 as the closing command. When the door is in motion the opposite direction input will cause a smooth reversal of manoeuvre (without passing through stop). In this mode, **AUTO CLOSE** is disabled by default, although in **OPTIONS**, by accessing this command it can be activated by selecting **YES**.

STOP ALT.

The **ALT. STOP** mode works in the same way as the **STANDARD** mode, except that if LL1 or LL2 is used while the door is moving, it stops. The next press will make the door continue the manoeuvre in the opposite direction to the previous one. In this mode, the **AUTO CLOSE** is disabled by default, although in **OPTIONS**, by accessing this command, it can be activated by selecting **YES**.

DEADMAN

The **DEADMAN** mode only allows the door to move while the LL1 or radio input is active (opening) or the LL2 input is active (closing). The manoeuvre is interrupted when the input in use is deactivated. In this mode, the safeties only pause the manoeuvre.

SEMI. DEADMAN

The **SEMI. DEADMAN** mode performs full opening in the normal way when using LL1 or LL2, but requires using either of the inputs in deadman mode to close.

AUXILIARY DEADMAN

The parameter **AUX DEADMAN** parameter allows the panel to temporarily operate in deadman mode when one of the safeties fails the test, allowing the door to be opened in case of problems. When this option is activated, in the event of a failure, simply press and hold the usual key or radio input for a few seconds.

MANOEUVER

PHASES

SAFETY TESTS

The safety tests phase is performed in the beginning of every maneuver before moving the gate. The controller first checks for obstructed safeties (corresponding led off in the board) that are relevant to the maneuver. If there is any obstructed safety it waits for them to enter idle state and will show a message in the display to this effect. Then the board checks the resistive values of safety edges and performs a test procedure on light barriers removing power from the transmitter to check the system is in order.

UNLOCKING

The unlocking phase performs many different functions simultaneously before starting the movement phase:

- ♦ Activates the garage light relay during the time interval specified by the **GARG LIGHT T** parameter. This parameter can be set to any time from 1 sec. to 240 sec., thus saving the need to use an external timer.
- ♦ Activates the electrolock relay if any of the relays is configured as such and the **ELECTROLOCK** parameter is set with a time interval.
- ♦ When the electrolock is activated and the maneuver will open the gate the controller performs a reversing stroke in soft stop speed (**OP SOFT VEL** parameter) with normal power (**OP NORMAL POW** parameter) for a duration specified by the **REVERS. STROKE** parameter.
- ♦ Performs preflashing through a relay configured for light beacon during the time interval specified by the **PREFLASH OP T** parameter for opening and the **PREFLASH CL T** for closing. Preflashing is managed following the mode specified by the **PREFLASH MODE** parameter. If the **FLASHING SEM.** parameter is set preflashing will be performed through a relay configured as red semaphore light.

MOVEMENT

The movement phase comprises the actual gate movement and management of the safety devices. First the red semaphore light is activated if any relay is set as such and the maneuver counters are incremented (once per gate movement direction). The electrolock, if activated in the previous phase, is held active until the time specified by the **ELECTROLOCK** parameter passes. If there is a relay set up as a beacon light it will be managed following the mode set in the **FLASH MODE MOV** parameter.

Motor speed and power are adjusted in different phases:

- ♦ Acceleration ramp: The acceleration ramp is performed at maximum power and goes from stopped motor to the transit speed in the time specified by the **OP ACCEL RAMP** parameter for opening and **CL ACCEL RAMP** for closing. The shorter the ramp time the more abrupt the speed change is, and the longer the ramp, softer the speed change.
- ♦ Transit: In transit the motor spins with the the speed and power adequate to the maneuver. Most maneuvers are performed in normal speed (**OP NORMAL VEL** for opening and **CL NORMAL VEL** for closing) and power (**OP NORMAL POW** for opening and **CL NORMAL POW** for closing). Deadman maneuvers before the first learning maneuver are performed in soft stop speed (**OP SOFT VEL** for opening and **CL SOFT VEL** for closing) and power (**OP SOFT POW** for opening and **CL SOFT POW** for closing).

continues on next page -->

MANOEUVER

- ♦ Soft stop ramp: If the **SOFT STOP** parameter is set, when the gate reaches the position set as a percentage of the gate limits (**OP SOFT STOP** for opening or **CL SOFT STOP** for closing), the controller starts the soft stop phase. The soft stop ramp regulates the speed and power from the ones used in transit to the ones set for the soft stop phase (**OP SOFT VEL** and **OP SOFT POW** for opening or **CL SOFT VEL** and **CL SOFT POW** for closing) and lasts the time set in the **OP SOFT RAMP** parameter for opening or the **CL SOFT RAMP** parameter for closing.
- ♦ Soft stop: if the **SOFT STOP** parameter is set the motor will spin using the soft stop speed and power (**OP SOFT VEL** and **OP SOFT POW** for opening or **CL SOFT VEL** and **CL SOFT POW** for closing).
- ♦ Deceleration before limit: if the **DCEL OP MARGIN** parameter when closing or the **DCEL CL MARGIN** when closing are greater than zero the controller will progressively decelerate when the remaining gate movement reaches the margin specified by the corresponding parameter, reaching the end with the speed specified by the **DCEL OP VEL** parameter when opening or the **DCEL CL VEL** parameter when closing.

The movement phase finishes either because the maneuver time runs out, a limit switch has been reached, the programmed encoder position has been reached (**VF1L**, **ABS ENC I POS** and **ABS ENC F POS** parameters) or, in pedestrian mode, the gate reaches the configured position (**PEDEST LIM** parameter). The maneuver time is set in the **OPEN TIME** parameter for opening and **CLOSE TIME** parameter for closing. When the maneuver is inverted the controller calculates the needed time using the current gate position as reference. If the gate does not reach its end point in this situation it is possible to apply some extra time (**EXTRA TIME** parameter).

Safeties can alter maneuvers (inversion, safety stop...). Ending a maneuver because of a safety is considered a cancellation and can be followed automatically by another maneuver (inversions).

When the opening movement phase ends

successfully, the red semaphore light is deactivated and the green semaphore light is activated.

LOCKING

The locking phase when closing, if an electrolock is installed, performs a final stroke in soft stop speed (**CL SOFT VEL**) and in normal power (**CL NORMAL POW** parameter) lasting the time specified by the **FINAL STROKE** parameter.

PAUSE

The pause phase is performed after opening if the **AUTO CLOSE** parameter is set. This phase lasts the time specified by the **AUTO CLOSE T** parameter for normal maneuvers, the **AUTO C PED T** parameter for pedestrian maneuvers and the **FAST PHOTO CLOSE** parameter for light barrier inversions. If a light beacon relay is configured it will follow the configuration set in the **FLASH MODE PAUS** parameter. When the pause ends a new closing maneuver starts.

If the **OPTIONAL AUTO** parameter is set, any key switch activation will terminate the pause phase. If **OPTIONAL AUTO** is not set but **KEY RES. AUTO** is set, key switch inputs will restart the pause timer, also when held.

If the **CLOSE ON BEAM** parameter is set with an specific time, a light barrier obstruction during pause will reset the timer to the value set in the parameter.

MANOEUVRE

SAFETY

The control panel has several safety devices that can affect the operation during operation: STOP, photocells, safety edge, amperometric sensor and encoder.

STOP

The STOP input allows the connection of a normally closed device for the emergency stop of the manoeuvre.

Activation of the STOP input will cause the motor to stop immediately and cancel the current manoeuvre; no matter what phase or state it is in.

PHOTOCELLS

The panel has a photocell input and a band input that can be configured as a photocell; both can be enabled and configured independently. These inputs work as normally closed contacts, so if you want to connect several photocells to the same input, it is necessary to connect them in series. If several photocells are connected to the same input of the panel, they will share the same configuration.

To be able to use a photocell input, the input must first be enabled using the **FOTOC. 1** parameter or the **EDGE 1** parameter. Once the input has been enabled, it is possible to configure the safety test behaviour for the input, the opening behaviour and the closing beha-

viour.

To activate the safety test the **TEST BEAM 1** parameter or the **TEST BEAM 2** parameter must be used. Once set, the default testing strategy is to test both before opening and closing. It is possible to adjust this strategy using the **TEST BEAM 1 OP**, **TEST BEAM 1 CL**, **TEST BEAM 2 OP** and **TEST BEAM 2 CL** parameters.

In order to test the photocells, it is necessary to be able to interrupt the supply voltage to the photocells, or in some cases, to provide them with a signal so that they can carry out the test themselves. For maximum flexibility, the panel provides two systems: terminal 18 is connected to the negative of the power supply input of the devices to be deactivated, or the garage light relay with **TEST** function can be used to interrupt other voltages or give a signal to a device.

Below all possible values for **BEAM 1 OPEN**, **BEAM 1 CLOSE**, **BEAM 2 OPEN** and **BEAM 2 CLOSE** are detailed.

NO	The light barrier is ignored.
PAUSE	The light barrier pauses the maneuver while obstructed. When unobstructed, the controller waits for three seconds and resumes the maneuver.
INVERT	The light barrier inverts the maneuver direction.
STOP	The light barrier stops and cancels the maneuver.
SHORT INV.	The light barrier inverts the maneuver direction during the time set in the SHORT INV. T. parameter and then stops and cancels the maneuver.
DELAYED INV.	When the light barrier is unobstructed the gate stops, waits during the time set in the DEL. INV. T. parameter and then inverts the maneuver.

MANEUVER

SAFETY EDGES

SAFETY EDGESThe panel has a safety edge input that can be enabled and configured. This input works by monitoring the connected resistive value and supports 8K2 or 4K1 resistive bands and contact bands, either normally open or normally closed. It is possible to configure this input as a second photocell, in which case the relevant test and configuration parameters will be activated. If you want to connect several strips to the same input, it is necessary to connect them in series if they are normally closed contact strips, and in parallel if they are normally

open or resistive contact strips. In the case of resistive strips, the panel only supports two connected in parallel on the same input, configuring the input for 4K1.

In order to use the band input, it is necessary to configure the input by modifying the parameter **EDGE 1**.

The possible options for the parameters **EDGE 1 APER** and **EDGE 1 CLOSE** are detailed below, with the selected action being applied when the safety is activated in the chosen direction.

NO	The safety edge is ignored.
INVERT	The safety edge inverts the maneuver.
STOP	The safety edge stops and cancels the maneuver.
SHORT INV.	The safety edge inverts the maneuver direction during the time set in the SHORT INV. T. parameter and then stops and cancels the maneuver.

CURRENT SENSOR

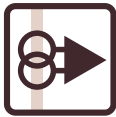

The BOX L VF1L controller monitors the current draw on each motor phase in real time so it can be displayed in the LCD screen and to implement three different protections:

- ♦ Obstacle detection: When the controller detects an abrupt rise in motor current draw or detects that it is higher than a configurable limit (**M1 OBST. LIM**) during a short span of time the obstacle detection safety activates. This safety only works if the **M1 SENSIB.** parameter is 1 or greater; this parameter set the sensitivity to rises in current draw, being 1 the lowest and 9 the highest. If this safety is activated the controller will log an error for future reference. NOTE: This safety does not work during speed ramps and performs best when the motor spins with reduced power.
- ♦ Overcurrent protection: If the controller detects that the motor current draw rises above a limit set in the **OC LIMIT** parameter for a brief span of time the maneuver will be cancelled immediately and an error will be logged for future reference.
- ♦ Shortcircuit protection: If the controller detects that the motor current draw rises above an internal limit close to the maximum supported by the board the maneuver is cancelled immediately and an error is logged for future reference.

OBSTACLE DETECTION

The controller has many means to detect an obstacle. The behaviour of the gate when one is encountered is set by the **PUSH SEC. OPEN** and **PUSH SEC. CLOSE** parameters in a similar fashion to safety edges (see table above).

MANOEUVER

ENCODER

When the encoder is enabled it can be used as a safety measure too. The controller monitors the time lapse between position changes and implements two protections::

- ♦ Obstacle detection: If the controller detects an abrupt rise in time between position changes the obstacle detection safety activates. This safety only works if the **M1 ENC SENS.** parameter is 1 or greater; this parameter set the sensitivity to rises in current draw, being 1 the lowest and 9 the highest. If this safety is activated the controller will log an error for future reference.. NOTE: This safety does not work during speed ramps.
- ♦ Locking detection: If the controller tries to make the motor spin but no significative position change is detected the maneuver is cancelled to avoid damage and an error is logged for future reference.

MOTOR

The BOX L VF1L allows independent control of speed and power for a 230VAC three-phase motor (delta wiring). Speed can be set between 10Hz (Hertz) and 100Hz (**OP NORMAL VEL, CL NORMAL VEL, OP SOFT VEL** and **CL SOFT VEL** parameters) and power can be set from 30% to 100% (**OP NORMAL POW, CL NORMAL POW, OP SOFT POW** and **CL SOFT POW**).

It is important to consider that three-phase motors are normally designed to operate at 50Hz and 100% power. Using these settings is equivalent to supplying the motor directly with three-phase voltage (230V). Changing the frequency, especially close to the limits may cause the motor to not move properly or to consume too much power and not run properly. Likewise, reduction of power may cause the motor not to rotate at the set speed or not to run properly. It is recommended not to make extreme adjustments without thorough testing.

The frame has two complementary braking systems: the electric brake and the mechanical brake. The electric brake is applied via the motor voltage phases and serves to force the motor to stop turning without friction, thus eliminating inertia and extending the life of the mechanical brake, if used. The mechanical brake is activated by an output relay and serves to ensure that the motor does not rotate autonomously while the switchgear is not operated. Translated with www.DeepL.com/Translator (free version)

ELECTRICAL WIRING DIAGRAM

1	230VAC phase
2	230VAC neutral
3	Earth terminal
4	Motor earth terminal
5	U motor phase
6	V motor phase
7	W motor phase
8	Flashing lamp output
9	
10	Garage light output contact
11	
12	Encoder power positive
13	ENC1 or B encoder input (VFIL-EA)
14	A encoder input (VFIL-EA)
15	Encoder power negative
16	Negative
17	Positive
18	15VDC power output for light barriers and others
19	Power negative for light barrier transmitter with autotest function
20	Opening limit switch
21	Closing limit switch
22	Light barrier 1 NC
23	Input common
24	Safety edge input
25	LL1 Input
26	Input common
27	LL2 Input

Fig.2

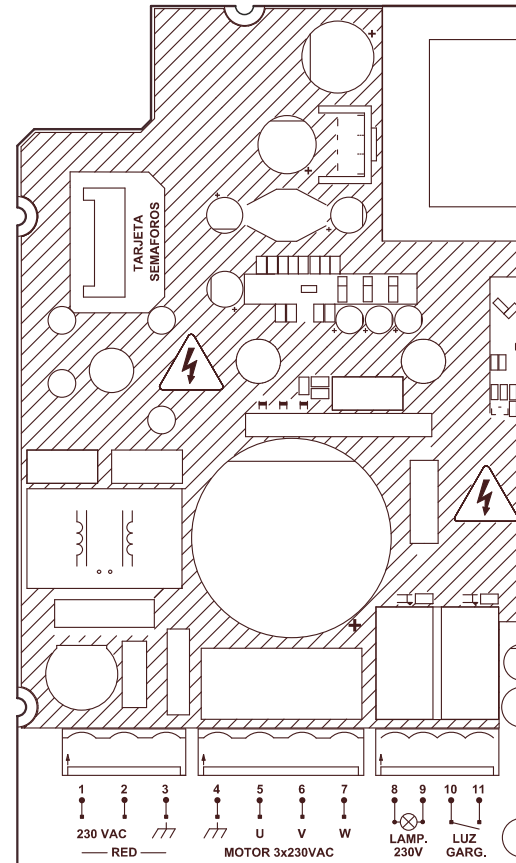

LIGHT BARRIER POWER DIAGRAM

See page 24 for correct shielding of the receiver

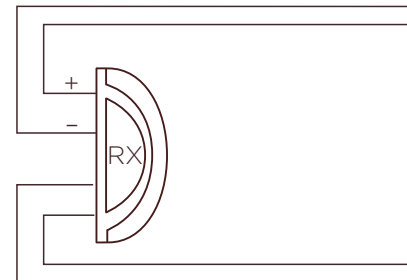

The negative of the light barrier transmitter must be connected to the common ground to facilitate the light barrier test function.

ACCESORIES AND PERIPHERALS

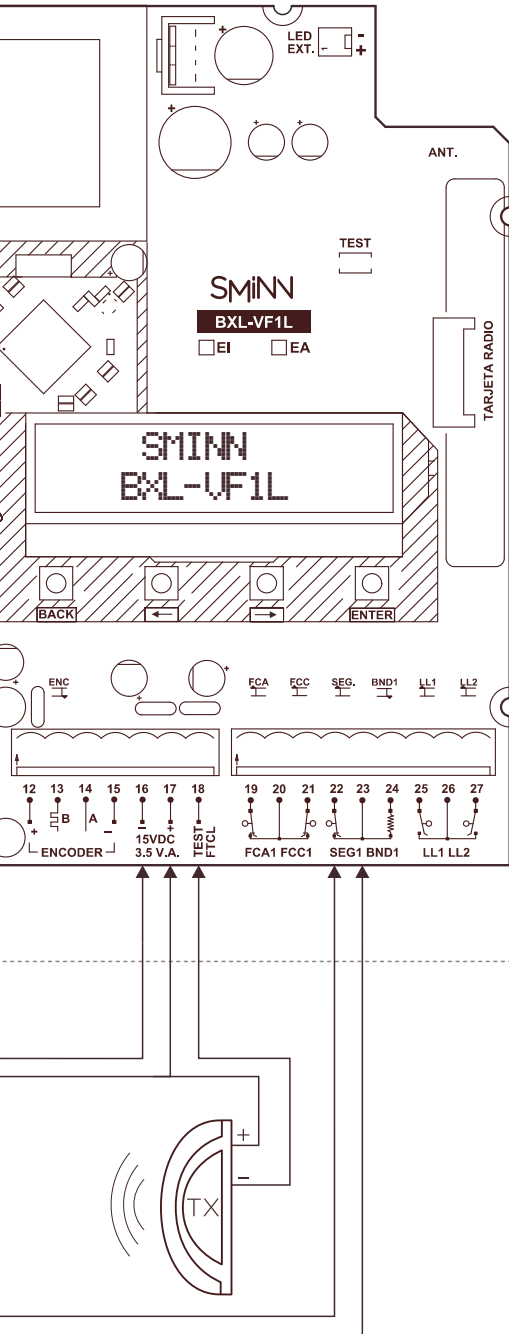

must be connected to pin 18 of the terminal block

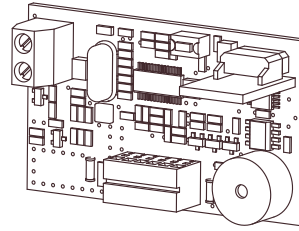

Radio card

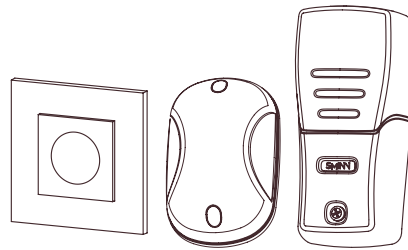

Transmitter-receiver light barrier set

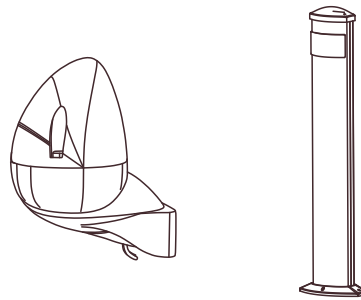

Beacon light and light barrier stand

ESPAÑOL

ENGLISH

FRANÇAIS

ITALIANO

PORTUGUÊS

DEUTSCH

NEDERLANDS

MANOEUVER

OUTPUTS

The panel has two relay outputs, one preconfigured as a flashing lamp and the other configurable. The configurable output has its own menu (called **GARG LIGHT FL**) and within it there are two parameters: **POLARITY** and **RELAY MODE**.

POLARITY: Allows configuring the output polarity between **NO CONTACT** (normally open) and **NC CONTACT** (normally closed). It is important to consider that the physical relay contact available in the terminal strip is normally open, so if the board is unpowered the relay will always open the contact no matter the configuration..

RELAY MODE: Allows selecting the function each relay will perform.

RELAY - GARAGE LIGHT

The **GARAGE LIGHT** mode uses the relay to deliver power or a signal to a device each time a maneuver begins during the time span specified by **GARG LIGHT T** parameter.

RELAY - FLASH LAMP

The **FLASH LAMP** mode uses the relay to deliver power to a beacon light during the unlocking phase (preflashing), the movement phase and during pause. It is possible to modify the behavior of the output in each phase (off, intermitent or on) using the **PREFLASH MODE**, **FLASH MODE MOV** and **FLASH MODE PAUS** parameters.

RELAY - BRAKE

The **BRAKE** mode uses the relay to unlock or lock the electromechanical brake of the motor. The brake is released just before spinning the motor and is lock immediately after stopping it.

RELAY - MAINTENANCE

The **MAINTENANCE** mode uses a relay to signal or power an external device when the maneuver partial counter rises above the limit set in the **MAINT. LIM.** parameter.

RELAY - SAFETY TEST

The **SEC. TEST** mode performs a safety test on devices that are powered externally or that need a test signal. The controller will activate the relay to perform the test and deactivate it when the safety switches state.

RELAY - ELECTROLOCK

The **ELECTROLOCK** mode activates an electrolock before opening the gate. Setting this mode for a relay enables other parameters related to the electrolock function (**ELECTROLOCK**, **REVERS. STROKE**, **FINAL STROKE**).

RELAY - RED SEMAPH

The **RED LIGHT IN** and **RED LIGHT OUT** modes use a relay to activate a red semaphore light for a given transit direction. If the **FLASHING SEM.** parameter is set preflashing will be performed in this relay too.

RELAY - GREEN SEMAPH

The **GREEN LIGHT IN** and **GREEN LIG. OUT** modes use a relay to activate a green semaphore light for a given transit direction.

RELAY - GATE STATE

The **GATE CLOSED** mode activates the relay while the gate is completely closed.

The **GATE OPENED** mode activates the relay while the gate is completely open.

The **GATE OPENING** mode activates the relay while the gate is opening.

The **GATE CLOSING** mode activates the relay while the gate is closing.

RELAY - IN PAUSE

The **IN PAUSE** mode activates the relay while the maneuver is in the pause phase.

MANOEUVER

DISPLAY

The LCD display shows during maneuver many useful runtime values easing maintenance and initial installation.

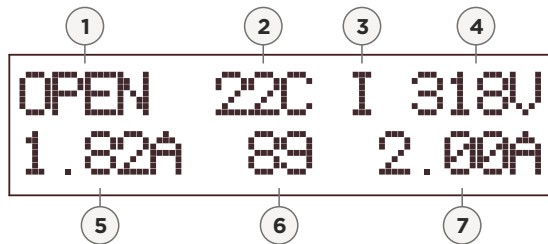

1. Current phase
2. Controller temperature
3. Input inhibition indication
4. Bus voltage
5. Real-time current draw
6. Percentage-based gate position / Remaining pause time.
7. Maneuver maximum current draw.

When idle, the controller might show four E in the display borders to indicate there are one or more logged errors. When entering the menu the controller will show one by one the logged error, waiting for ENTER to be pressed in between. NOTE: The controller will still work normally even if there are logged errors.



ENCODER (VFIL)

It is possible to use an incremental encoder (**ENCODER** parameter) to enhance the precision of the gate position management and have some additional safety measures. The controller supports both one channel encoders (**1 CHANNEL**).

For more information on safety related encoder settings check page 13.

ENCODER (VFIL-EA)

It is possible to use an absolute encoder via RS485 bus (**ENCODER** parameter) to control the gate position.

The learning maneuver automatically detects the correct encoder polarity. Before the actual learning maneuver the installer is prompted to move the gate to the opening and closing positions to learn their encoder values. These positions can be adjusted after the learning maneuver using the **ABS ENC I POS** and **ABS ENC F POS** parameters.

For more information on safety related encoder settings check page 13.

OPTIONS

	TEXTO LCD	VALOR POR DEFECTO	PAGINAS
AUTOMATIC CLOSING Enables automatic closing after the pause phase	AUTO CLOSE	YES	8, 10
FAST LIGHT BARRIER CLOSING The pause after a photocell reversal lasts for the time set as photocell closure. Only visible if CLOSE ON BEAM is not NO	FAST PHOTO CLS	NO	10
OPTIONAL AUTO Terminates the pause phase with an impulse.. Only visible if AUTO CLOSE is enabled	OPTIONAL AUTO	NO	10
AUTO DELAY ON KEY Restarts the pause phase with each comand impulse. Only visible if OPTIONAL AUTO is disabled and AUTO CLOSE is enabled	KEY RES. AUTO	YES	10
BEAM 1 Enables control of he light barrier input	BEAM 1	NO	11
TEST BEAM 1 / 2 Enables safety test on the connected light barrier	TEST BEAM 1 TEST BEAM 2	NO NO	11
TEST BEAM 1 / 2 OPENING/CLOSING Enables the light barrier safety test before a maneuver in the corresponding direction.	TEST BEAM1 AP TEST BEAM1 CR TEST BEAM2 AP TEST BEAM2 CR	NO NO NO NO	11
LIGHT BARRIER 1 / 2 MODE Establishes the behaviour of the light barrier when opening or closing. Options: NO / PAUSE / INVERT / STOP / SHORT INV. / DELAYED INV.	BEAM 1 OPEN BEAM 1 CLOSE BEAM 2 OPEN BEAM 2 CLOSE	NO INVERT NO INVERT	11
EDGE 1 Enables control of the safety edge input. Supports resistive and contact safety edges. Options: NO / SK2 / 4K1 / NO CONTACT / NC CONTACT	EDGE 1	NO	11, 12
EDGE 1 MODE OPEN / CLOSE Establishes the behaviour of the safety edge when opening or closing. Options: NO / STOP / SHORT INV. / INVERT	EDGE 1 OPEN EDGE 1 CLOSE	NO INVERT	12
OBSTACLE DETECTION OPEN / CLOSE Establishes the behaviour of the obstacle detection system when opening or closing. Options: NO / STOP / SHORT INV. / INVERT	PUSH SEC. OPEN PUSH SEC. CLOSE	STOP SHORT INV.	12
SOFT STOP Enables soft stop	SOFT STOP	YES	7, 10
CLOSE ON BOOT Perform a closing maneuver after powering on the controller.	CLOSE ON BOOT	NO	

OPTIONS

	TEXTO LCD	VALOR POR DEFECTO	PAGINAS
PREFLASH MODE Establishes the behaviour of the light beacon during the unlocking phase. Options: NO / INTERMITTENCE / ON	PREFLASH MODE	INTERMITTENCE	9, 16
FLASH MODE MOVEMENT Establishes the behaviour of the light beacon during the movement phase. Options: NO / INTERMITTENCE / ON	FLASH MODE MOV	INTERMITTENCE	9, 16
FLASH MODE PAUSE Establishes the behaviour of the light beacon during the pause phase. Options: NO / INTERMITTENCE / ON	FLASH MODE PAUS	NO	10, 16
SEMAPHORE CARD Sets the connected semaphore card	SMPH CARD	TSMF20	
FLASHING SEMAPHORE Uses the red semaphore light for preflashing.	FLASHING SEM.	NO	9, 16
IMMEDIATE DISCRIMINATION Sets whether in discriminatory mode the green traffic light is to be switched on immediately at the start of the manoeuvre.	IMM. DISCR.	NO	
AUXILIARY DEAD MAN If the safety test phase detects any failure the mode switches to dead man temporally.	AUX DEAD MAN	NO	8
ENCODER Enables maneuver control via encoder. Options (VFIL): YES / NO Options (VFIL-EA): NO / SMINN / MFZ / SOMMER / GFA	ENCODER	NO	17
ENCODER POLARITY Establishes the spin direction interpreted by the encoder. Options: NORMAL / INVERTED	ENC POLARITY	NORMAL	7
OPENING LIMIT SWITCH (VFIL-EA) Enables the opening limit switch input when encoder is selected.	OPEN LS	NO	
CLOSING LIMIT SWITCH (VFIL-EA) Enables the closing limit switch input when encoder is selected.	CLOSE LS	NO	
LL1/LL2 BLOCK Blocks any signal in the LL1 / LI2 keyswitch inputs. Only visible with enabled password.	LL1 BLOCK LL2 BLOCK	NO NO	8
RADIO ALTERNATING STOP Makes the radio card input work in alternating stop mode.	RADIO ALT STOP	NO	8
POLARITY OF GARAGE LIGHT RELAY Sets the polarity of the output contact of each relay. Options: NO CONTACT / NC CONTACT	GARG LIGHT RL / POLARITY	NO CONTACT	16
GARAGE LIGHT RELAY MODE Sets the relay function Options: See page 16	GARG LIGHT RL / RELAY MODE	GARAGE LIGHT	16
INVERT MOTOR Establishes the spin direction of the motor.	INVERT MOTOR	NO	7
INVERT TEST Sets the polarity of the test output.	INVERT TEST	NO	

ESPAÑOL

ENGLISH

FRANÇAIS

ITALIANO

PORTUGUÊS

DEUTSCH

NEDERLANDS

TIMINGS

	LCD TEXT	DEFAULT VALUE	ADJUSTMENT	PAGES
Opening time	OPEN TIME	15 sec	0-1800 sec	7, 10
Closing time	CLOSE TIME	15 sec	0-1800 sec	7, 10
Automatic closing time	AUTO CLOSE T	15 sec	1-60000 sec	10
End position of pedestrian maneuver	PEDEST LIM.	50%	0-100 %	10
Pedestrian automatic closing time	AUTO C PED T	15 sec	1-60000 sec	10
Opening soft stop position	OP SOFT STOP	0%	0-100 %	7, 10
Closing soft stop position	CL SOFT STOP	0%	0-100 %	7, 10
Extra time	EXTRA TIME	0 sec	0-1800 sec	10
Close on beam time	CLOSE ON BEAM	NO	NO/2-240 sec.	10, 18
Delayed inversion time	DEL. INV. T.	5 sec	0-1800 sec	11
Short inversion time	SHORT INV. T.	1,5 sec	0-100 sec	11, 12
Electrolock time	ELECTRIC LOCK	NO	NO/1-10 sec	9, 16
Reversing stroke time	REVERS. STROKE	0 sec	0-1800 sec	16
Final stroke time	FINAL STROKE	0 sec	0-1800 sec	16
Opening motor normal power	OP NORMAL POW	100%	30-100 %	9, 13
Closing motor normal power	CL NORMAL POW	80%	30-100 %	9, 10, 13
Opening motor normal speed	OP NORMAL VEL	50Hz	10-100Hz	9, 13
Closing motor normal speed	CL NORMAL VEL	50Hz	10-100Hz	9, 13
Opening motor soft power	OP SOFT POW	80%	30-100 %	9, 10, 13
Closing motor soft power	CL SOFT POW	80%	30-100 %	9, 10, 13

TIMINGS

	LCD TEXT	DEFAULT VALUE	ADJUSTMENT	PAGES
Opening motor soft speed	OP SOFT VEL	25Hz	10-100Hz	9, 10, 13
Closing motor soft speed	CL SOFT VEL	25Hz	10-100Hz	9, 10, 13
Opening acceleration ramp time	OP ACCEL RAMP	1,5 sec	0-100 sec	9
Closing acceleration ramp time	CL ACCEL RAMP	1,5 sec	0-100 sec	9
Opening soft stop ramp time	OP SOFT RAMP	1,5 sec	0-100 sec	10
Closing soft stop ramp time	CL SOFT RAMP	1,5 sec	0-100 sec	10
Opening deceleration final speed	DCEL OP VEL	10 Hz	0-100 Hz	10
Closing deceleration final speed	DCEL CL VEL	10 Hz	0-100 Hz	10
Opening deceleration margin	DCEL OP MARGIN	0 %	0-15 %	10
Closing deceleration margin	DCEL CL MARGIN	0 %	0-15 %	10
Absolute encoder closed position (VFIL-EA)	ABS ENC I POS	0	0-65536	7, 10, 17
Absolute encoder opened position (VFIL-EA)	ABS ENC F POS	0	0-65536	7, 10, 17
Opening preflashing time	PREFLASH OP T	0 sec	0-1800 sec	9
Closing preflashing time	PREFLASH CL T	0 sec	0-1800 sec	9
Garage light time	GARG LIGHT T	0 sec	0-60000 sec	9, 16
Current sensing obstacle detection sensitivity	M1 SENSIB.	5	0-9	7, 12, 23
Encoder obstacle detection sensitivity	M1 ENC SENS.	5	0-9	13
Obstacle detection current limit	M1 OBST. LIM.	3 A	0-16 A	7, 12, 23
Overcurrent limit	OC LIMIT	10 A	0-16 A	12

ESPAÑOL

ENGLISH

FRANÇAIS

ITALIANO

PORTUGÊS

DEUTSCH

NEDERLANDS

MAINTENANCE

This menu allows checking maneuver counters, input status, setting a maintenance password and loading default values.

VERSION

Shows the firmware version of the controller.

PARTIAL COUNTER

Shows the number of maneuvers performed since the last counter reset..Pressing ENTER will prompt for counter reset..

TOTAL COUNTER

Shows the number of maneuvers performed since the controller was last reset to default values.

COUNTERS

Displays activation counters for all inputs as well as operating times of the switchboard and the motor.

INPUT STATUS

Shows the input status in the display. NOTE: Only enabled inputs will be shown.

LAMP RL / GARG LIGHT RL

Allows each relay to be activated in deadman mode to test the connected peripherals.

OPEN/CLOSE

From this menu it is possible to control the motor in dead man mode with the ENTER key. This function ignores most of the controller safety measures so its use is only recommended to check the spin direction. It is recommended to use the <- and -> keys to move the gate in dead man mode when the controller is idle.

ENCODER

Shows the current gate position in form of encoder pulses.

ENCODER RATIO

Displays the relationship between motor rotational speed and time between pulses.

MAX CONS.

Shows the maximum current draw registered during normal maneuvers.

MAX CON LEARN

Shows the maximum current draw registered during a learning maneuver.

DEFAULT VALUES

Resets all configuration to default values (Factory defaults).

MENU MODE

It allows changing the menu system to an advanced version (explained later).

MAINT. LIM.

Allows setting a partial counter value from which the controller will blink the external power LED to indicate maintenance is needed.

It is possible to have a relay close its contact in this situation by setting it to the **MAINTENANCE** function.

ENABLE PASSWD

Activates a password prompt to access the configuration menu. The default password is 1234.

CHANGE PASSWD

Allows changing the password.

LANGUAGE

This allows changing the menu language.

ERROR LOG

The BOX L VF1L controller stores while it is powered the errors that occur during maneuvers. When there are errors to check the board will display an E in each border of the display. Find below a list of possible errors.

FAILED TEST SEG1/SEG2

Safety test has failed for the shown light barrier. Check the wiring and power.

CONFIG ERROR

An error has been detected in the configuration storage memory. If the error persists contact the technical service.

LOG ERROR

An error has been detected in the log storage memory. If the error persists contact the technical service.

OVERCURRENT MOTOR

A current draw higher than the configured limit has been detected.

MOTOR OC IGBT

An overcurrent event has been detected in the power circuit.

MOTOR OC

An overcurrent event has been detected in the hardware shortcircuit detector.

OBSTACLE MOTOR SENS

An obstacle has been detected using the current sensor. If no actual collision happened, reduce **M1 SENSIB**.

OBSTACLE MOTOR ENC

An obstacle has been detected using the encoder. If no actual collision happened, reduce **M1 SENS. ENC**.

OBSTACLE MOTOR LIM

An obstacle has been detected because of the configured current limit. If no actual collision happened, increment **M1 LIM. FFES**.

ENCODER STOP

The controller detected that the motor could not spin properly using the encoder. This can happen because the motor itself is locked or because it reached a limit.

LEARNING MISSING

It is mandatory to perform a learning maneuver before operating the gte normally.

SEC HELD

At least one safety is held active before starting the maneuver.

IGBT TEMP TOO HIGH

The power electronics temperature has risen above the safety limit.

LOW BUS VOLTAGE

The controller does not receive enough input voltage or the motor is demanding more power than the controller can output.

INPUTS NOT AVAILAB.

The input reading circuit has stopped working. If the problem persists contact technical service.

ENCODER NOT AVAILAB.

The encoder reading circuit has stopped working. If the problem persists contact technical service.

ERROR ENCODER

Encoder readings are incorrect or unstable. Check the wiring, possible interference and encoder physical state.

LIGHT BARRIER SHIELDING

Many light barriers are particularly sensitive to electromagnetic noise generated by inverters or modulating electronics. If the light barrier installed is working correctly when the motor is stopped but fails when in motion, it is being affected by this noise.

To solve this problem, the first thing to do is to make sure that the light barrier is correctly aligned and that the distance is not greater than that specified in the specifications.

If the problem persists :

- Supply the light barrier receiver with direct current either from the control panel power supply output (terminals 16 and 17) or from an external power supply.
- Run a short cable from the negative power supply terminal of the photo barrier receiver to the post or metal structure of the gate on which it is mounted, as shown in the figure below.

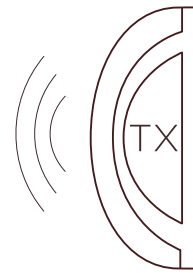
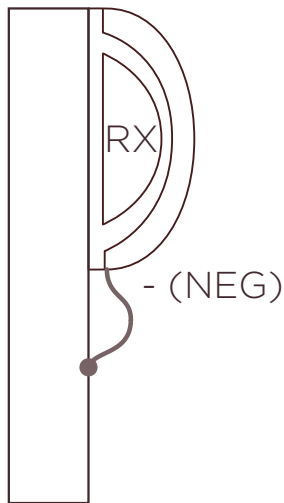

WARRANTY

This product has undergone a complete TEST during its manufacturing process that guarantees its reliability and proper operation. The manufacturer provides 24 months of warranty to the product from the date printed in the product and against any anomaly that it may present in its appearance or operation.

Any damage caused by third parties, natural causes (flooding, fire, lightning, etc), arising from improper handling or installation, vandalism or any other cause non attributable to the manufacturer will void the warranty.

The warranty only covers repairs or replacement of the damaged device. Any expenses derived from assembling, travelling, transport, natural wear of parts, etc., and, in general, any expenses that are not part of the repairs or replacement of the damaged element of the system are excluded.

The installer/provider will ask the manufacturer for a RMA number or authorization for transport of the system in warranty. Without this previous requisite, the manufacturer will not be able neither to process nor provide warranty service.

WASTE OF ELECTRICAL AND ELECTRONIC DEVICES (WEEE)

In accordance with the European Directive 2012/19/EU about waste electrical and electronic equipment (WEEE), the presence of this symbol (see symbol at the bottom of this text) in the product or in the packaging, means that this article shall not be disposed in local non-classified waste streams.

It is the user's responsibility to dispose this product taking it to a collection point designed for waste recycling of electrical and electronic devices. The separate collection of this product helps optimize the waste sorting and recycling of any recyclable material and also decreases the impact on health and the environment. For more information about the correct wasting of this product, please contact the local authority or the distributor where you acquired this product.



NOTES



A series of 20 horizontal lines spaced evenly down the page, providing a template for writing notes.

NOTES



A series of 20 horizontal lines for writing notes, spanning the width of the page.

ESPAÑOL

ENGLISH

FRANÇAIS

ITALIANO

PORTUGÊS

DEUTSCH

NEDERLANDS

TECHNICAL CHARACTERISTICS

Power supply	230VAC
Maximum load	1CV / 0,75kW
AC main fuse	6A
Power outputs	15VDC 3,5W
Power outputs protection	Rearmable fuses
Maneuver control inputs	7 high insulation optocoupled inputs 1 analog
Plug-in cards	Radio, traffic lights
LCD display	2x16 characters Chip-on-glass technology - Backlight
Working temperature	-20°C / 70°C
Case	ABS
Dimensions	L280 x W196 x H90 mm
Weight	1600 gr
Watertightness	IP54 (IP65 with cable glands)

CE DECLARATION OF CONFORMITY

The company ELSON ELECTRÓNICA, S. A.
Pol. Torrelarragoiti, P6 - A3
48170 Zamudio - Vizcaya (SPAIN)

Declares:
The product BOX L VF1L motor controller
Manufactured
Under the trademark **SMINN**
For use in Residential, Commercial or
light industry environments.

This device meets the provisions as long as its usage is compliant to what was envisaged, having applied the following regulations.

Directive 2014/30/EU - Electromagnetic compatibility

Directive 2014/35/EU - Low voltage

Directive 2006/42/EC - Machinery

Directive 2011/65/EU - RoHs

Directive 2012/19/EU - WEEE

Zamudio - 02.21.2020



José Miguel Blanco Pérez
Chief technical officer

SMINN

innovative in electronics

www.sminn.com
info@sminn.com

Rev.1521-1BB

VF1L EXPLOSION

Fig3

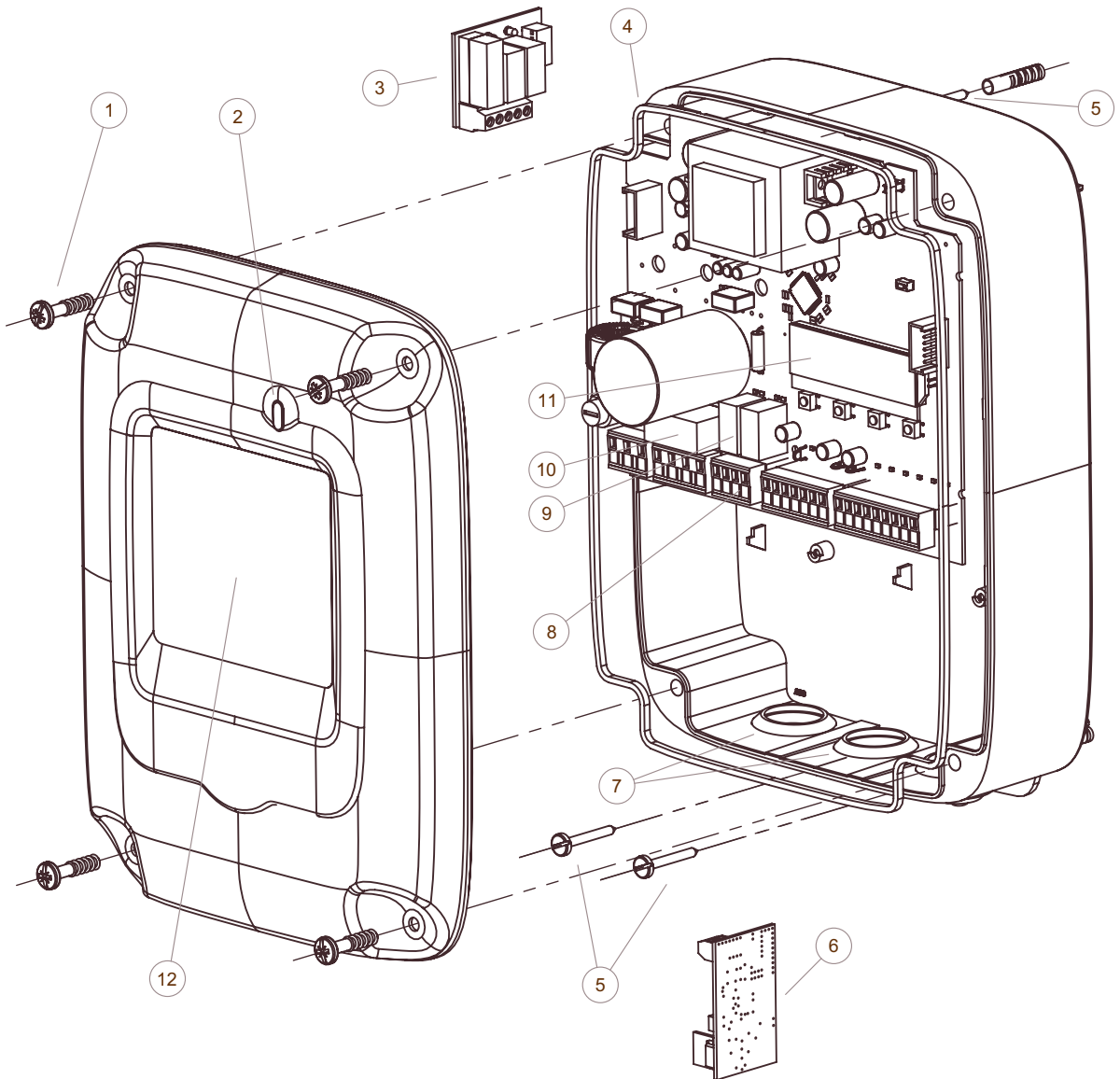

- 1. Captive screws
- 2. Power status LED
- 3. Traffic light card (optional)
- 4. Vacuum rubber gasket
- 5. External fixing with just three screws
- 6. Radio card (opcional)

- 7. Pass-throughs for 16 / 24mm pipes
- 8. Plug-in terminal blocks
- 9. Power relays
- 10. Bus load relays
- 11. Display
- 12. Frontal space for installer/revision sticker

ESPAÑOL

ENGLISH

FRANÇAIS

ITALIANO

PORTUGÊS

DEUTSCH

NEDERLANDS

SMiNN

innovative in electronics

